

AVIDYNE® IFD540

FMS|GPS|NAV|COM



Avidyne IFD540 FMS/GPS/NAV/COM sets a new standard for integration in aviation navigation systems. Designed for the rigorous demands of military and special-mission aircraft. The IFD540 flight management system provides VHF COM/NAV tuning via wired Cross-sync interface allowing tandem control of VHF communication and navigation as well as hybrid touch, flight glove compatibility. The IFD540 GPS Navigators were designed with real world flying conditions in mind. Every detail and function of the IFD540 is engineered with purpose: to make flying simple, safe and more enjoyable.

- **Hybrid touchscreen with traditional knobs and buttons**
- **Moving map with extensive airspace, terrain, navaid, and airport display capability**
- **Display of XM or ADS-B weather with full graphics as an overlay on the map**
- **Traffic display from TCAS, TAS, or ADS-B**
- **WiFi Integration with ForeFlight® and a host of other EFBs**
- **Optional integrated VHF Com, VOR, localizer and glideslope radio**
- **Class B NVIS compatibility available in compliance with RTCA/DO-275, MIL-L-85762A, and MIL-STD-3009 as required**
- **VHF COM/NAV Tuning via wired Cross-sync Interface allowing tandem control of VHF Communication and Navigation**
- **Optional integrated TAWS**

Avidyne IFD540 - The Right Fit

Specifications

Display

- 5.7" Diagonal w/ touchscreen
- Full VGA - 640x480 pixels
- 65,535 colors
- Ultrabright sunlight readable w/ LED backlighting

Dimensions

- Width: 6.30" (16.0cm)
- Height: 4.60" (11.7cm)
- Depth: 11.00" (27.5cm) behind panel including connector

Weight

- IFD550 - 9.19 lb (4.17 kg)
- IFD540 - 8.79 lb (3.99 kg)
- IFD545 - 7.48 lb (3.39 kg)
- IFD510 - 7.13 lb (3.23 kg)

Power Requirements

- 11 - 33VDC
- 4.4A/6.5A Xmit @ 14vdc
- 2.2A/4.0A Xmit @ 28vdc

GPS

- 16-Channel GPS/SBAS Receivers
- RTCA DO-178B and DO-254 Level B,
- RTCA DO-160E
- Meets DO-229D, Beta Class 3
- Accuracy:
 - Autonomous Position
 - 3 meters (CEP 50%)
 - 5 meters (95%)
 - SBAS Differential Position
 - 1 meter (CEP)
 - 3 meters (95%)
- Velocity Accuracy 0.1 knots (95%)
- Dynamics:
 - Acceleration : 10g max
 - Speed : 1,000 knots
 - Altitude : 50,000 ft

Optional VHF & VOR/LOC

- 16 Watt transmitter (Class 3, 5)
- Simultaneous reception of two channels, voice or data
- 8.33KHZ or 25KHZ Operation (Class C, E)
- VOR - RTCA DO-196
- LOC - RTCA DO-1965
- UHF GS - RTCA DO-192

Warranty

- 2 year warranty
- AeroPlan™ extended warranty available

I/O

See website for complete list of Interfaces. www.avidyne.com

Power Requirements

- 10 Watts nominal
- Optional 16Watt (for 28vdc installations only)

Environmental

- DO 160E
- To 50,000 ft.
- -20C to +55C Operating
- +70C Short Term

Cooling

- Built in cooling
- External cooling provision available

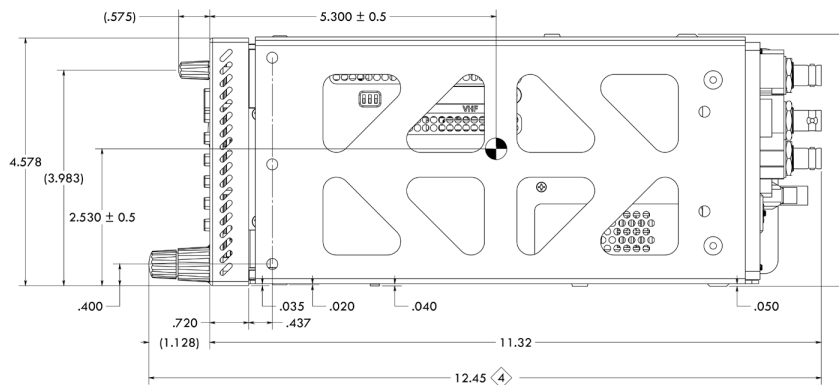
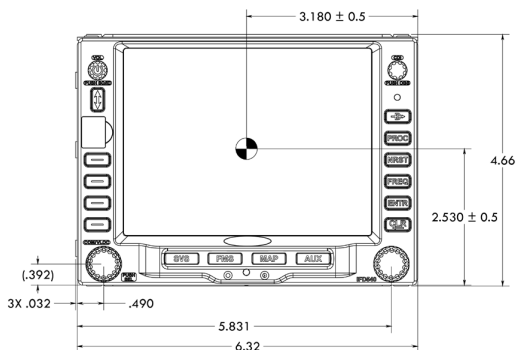

Fully Functioning Trainer "Simulator" IFD Trainer for Ipad®



- **Fly a mission**
- **All functions & features of the IFD available in the trainer**
- **Built-in tutorial videos**
- **Built-in operator manuals**
- **Great tool for ground school enhancement**

